

D728B: Insafe+ PMo LoRa Technical Guide

02/11/20

- 1. PRESENTATION 3**
 - 1.1 INTRODUCTION TO THE PRODUCT 3
 - 1.2 PRODUCT SCHEME 4
 - 1.3 DETAILED SPECIFICATIONS 5
- 2. INSTALLATION 6**
 - 2.1 INSTALLATION KIT 6
 - 2.2 INSTALLATION LOCATIONS 7
 - 2.3 INSTALLATION OF PMO..... 7
 - 2.4 PRODUCT STARTUP 9
- 3. DESCRIPTION OF PAYLOAD 10**
 - 3.1 GENERAL DESCRIPTION 10
 - 3.2 REAL TIME FRAME 11
 - 3.3 PRODUCT STATUS FRAME 13
 - 3.4 POSITIONING FRAME 15
 - 3.5 ENERGY STATUS FRAME 16
- 4. REVISION HISTORY AND PRODUCT BATCH NUMBER..... 17**
 - 4.1 TECHNICAL GUIDE CHANGELOG..... 17

1. Presentation

1.1 Introduction to the product

INSAFE+ PMo is a new generation connected Particulate Matter Sensor that also includes a temperature, humidity, and pressure sensor.

Its embedded GPS and wide range of available wireless protocols (Sigfox, Lora, Enocean, etc.) make this product easy to deploy.

INSAFE+ PMo can be powered with solar panel or using power grid, and a battery prevents blackout in measuring and sending data.

It is an ideal product for connected cities, tertiary buildings, public establishments that are concerned about monitoring pollution.

Product benefits:

- > PM₁₀, PM_{2.5}, PM₁, temperature, humidity and pressure sensor.
- > Wireless sensor for easy and fast installation.
- > A wide range of wireless protocols: Sigfox, LoRa, Enocean.
- > Location automatically computed by internal GPS
- > Embedded accelerometer to detect fall & theft
- > Up to 10-year operation.
- > Free maintenance and autonomous.
- > Product and sensors status automatically checked every day.
- > Easy to install and start.

Applications:

- > Control of outdoor air quality in residential premises and public places.
- > Monitoring pollution in cities, near road.
- > Environmental Impact Assessment.



Basic functions:

- > Measurement of Particulate Matter (10, 2.5 and 1), pressure, temperature and humidity every 15 minutes
- > Sending the GPS coordinates at the start of the product or its movement.

Advanced features:

- > Product status to monitor battery life, solar panel state, sensors states.
- > Fall detection.
- > Bad Positioning detection.
- > Solar panel state monitoring such as dusty solar panel.

1.2 Product scheme

L28 x l20 x P6,5 cm

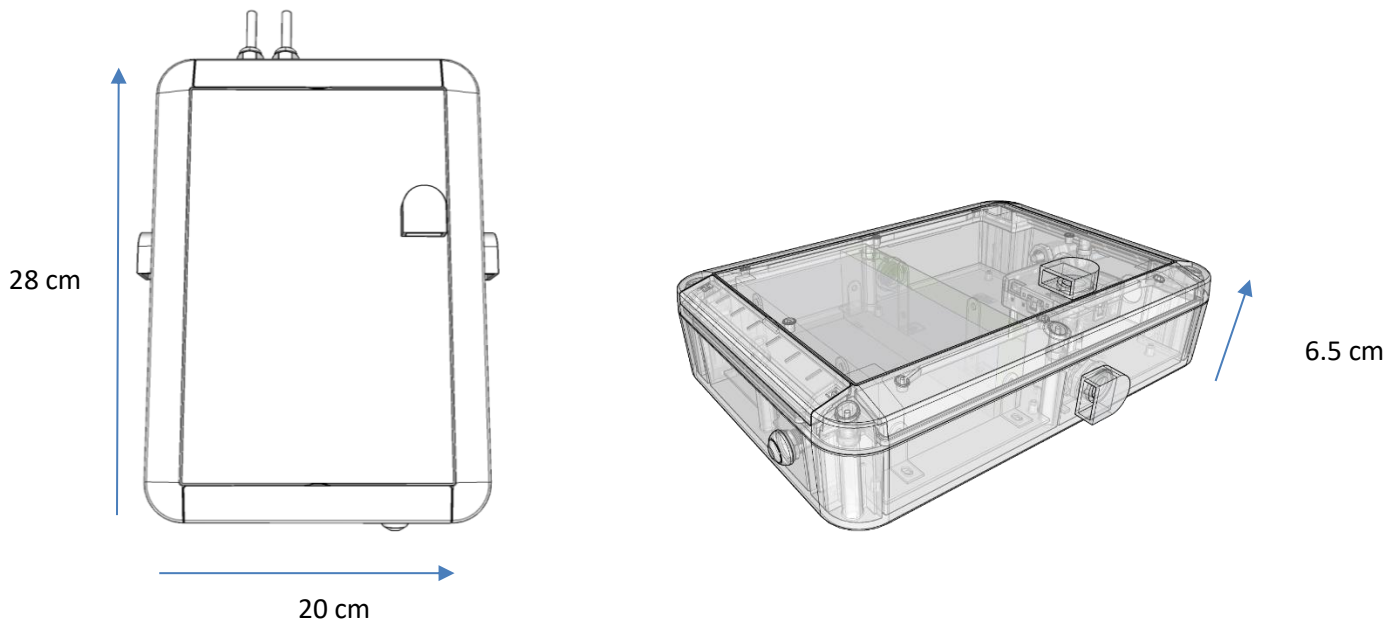

1.3 Detailed specifications

Product terms of use

- > Outdoor environment.
- > UV resistant case
- > Temperature: -20°C to +70°C
- > Relative humidity: from 0 to 95% RH non-condensing.
- > Rainproof enclosure

Sensors and measurements:

	PM	Temperature	Humidity	Pressure
Measurement uncertainty (typ.)	15% (PM2.5); 25% (PM1, PM10)	±0.3 °C	±2 %RH	1hPa
Resolution	0.1ug/m3 - 1pcs/mL	0.1°C	1 %RH	1hPa
Measuring range	0 – 1000 ug/m3 0 – 65000 pcs/mL	-30 – 70 °C	0 – 100 %RH	300 – 1200hPa
Measuring period	15 min	15 min	15 min	15 min

Certifications

The product is compatible with the following directives and standards:

Directives

- Radio Equipment Directive (RED) 2014/53/EU
- 2011/65/EU (RoHS) Directive

Standards :

- EN 62368-1
- EN 301 489-1 V2.2.0
- EN 301 489-3 V2.1.1
- EN 300 220-2 V3.2.1
- EN 62479 : 2010

2. Installation

Find on our website, tutorials describing the functioning of our different products : www.nexelec.fr

2.1 Installation Kit

The PMo installation kit includes:

- One PMo station.
- A mounting support for the PMo to screw in case the product must be fixed to a post or a tree.
- One bag of two clamps to fix the PMo station to a post or a tree.

The solar panel version of PMo also includes:

- A solar panel.
- A holder for the solar panel.
- One bag of two clamps to fix the holder to a post or a tree.

PMo station can also be fixed against a wall with 4 screws. In this case, do not screw the mounting support for the PMo.



Figure 1: Installation kit of the solar panel version of the PMo.

2.2 Installation locations

Recommended locations outdoor

It is recommended to install the product:

- More than 1.5 meter above the ground.
- In a south exposure if the product is powered by a solar panel.

In order to protect the product from direct sun exposure, we recommend placing it under the solar panel as shown in the picture below.



Locations to avoid

Do not install the PMo:

- Less than 1m from the ground.
- On a support likely to move.
- On a leafy tree that can hide the sun too much (for PMo with solar panel).

2.3 Installation of PMo (solar panel version)

First, the solar panel and its holder must be screwed together.

Then, screw the mounting support to the back of the PMo.

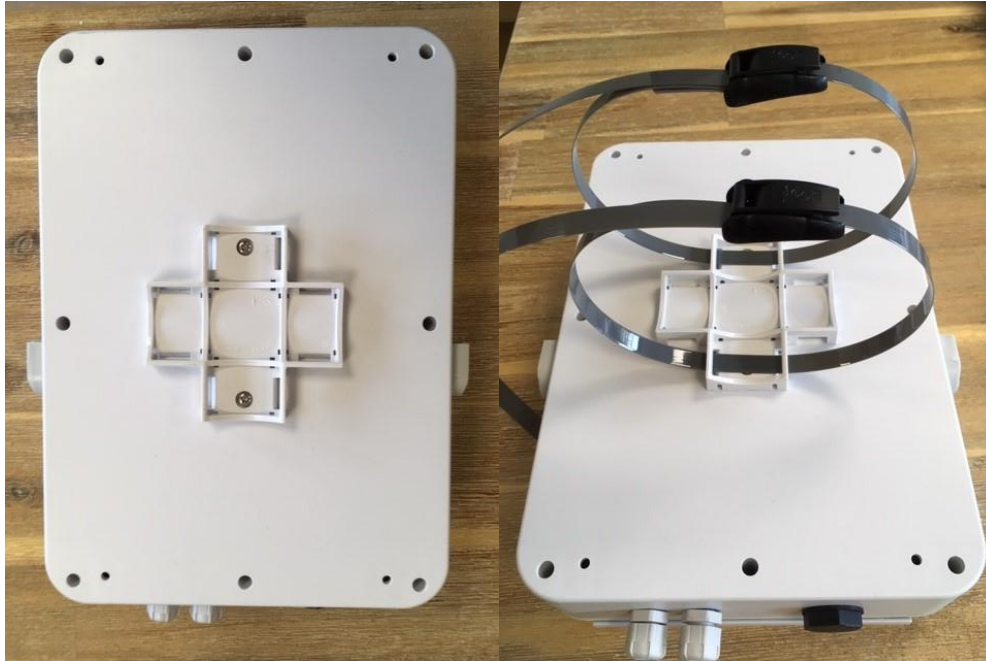

When the location is chosen (see above [Installation recommendations](#)), the solar panel has first to be fixed to the post.

Two people are required to fix the solar panel. The first one must carry the solar panel and its holder against the post or tree. The other one must tighten the two clamps around the post as shown in the picture below.



The same operation must be done for the PMo station. Be careful with its orientation, the solar cables must be oriented upwards and the button downwards.

The last step consists in plugging the solar cables with the station's cables.

2.4 Product Startup

When the station and its solar panel are fixed and connected, make two short pushes on the button. You will hear a short buzzer noise. If the joined with Lora gateway is successful, the blue led of the button will light up for 10 minutes and the first data will be sent within 10 minutes. In case the joined failed, the led will blink slowly.

The graph below shows the different possible interactions with the product by pushing the button in different ways.

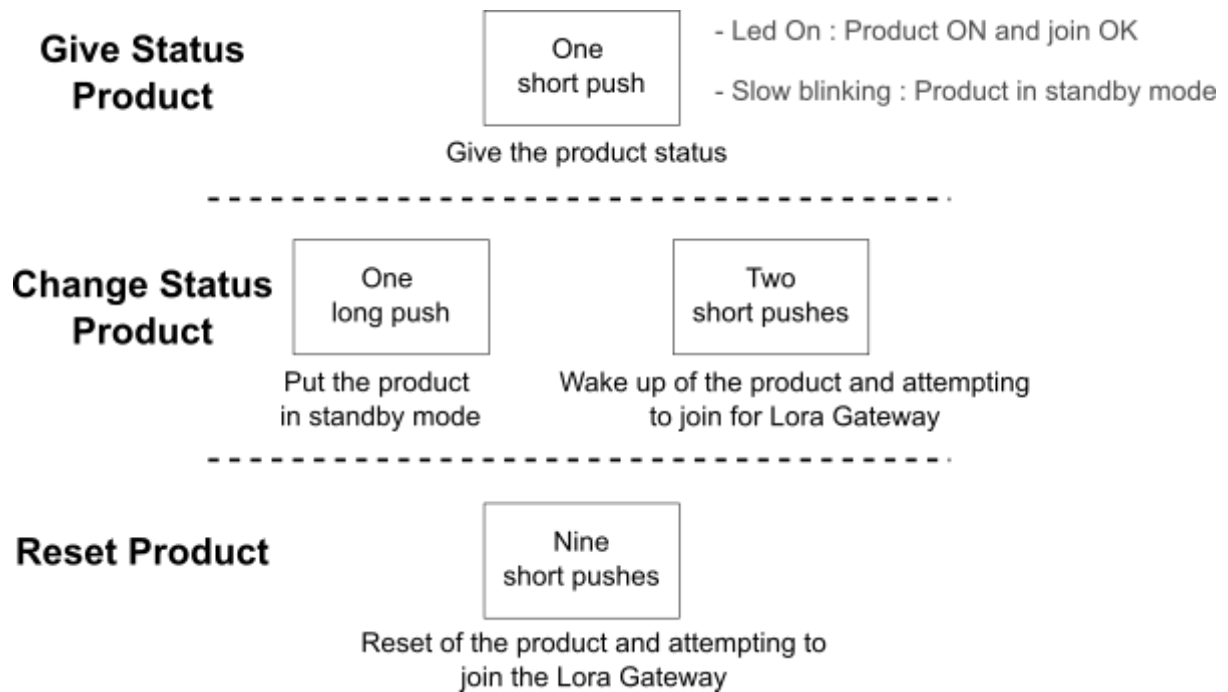

Note: A physical reset is also provided. Insert a needle into the hole, to the left of the button, and press two to three seconds to restart the product. After a physical reset, no need to press the main button, the product will attempt to join the gateway and start the measure on its own.

3. Description of payload

3.1 General description

Insafe+ PMo measures PM10, PM2.5, PM1, Temperature, Humidity and Pressure to analyze outdoor air quality. Insafe+ PMo includes advanced features such as real time measurement, product status, energy status and product positioning thanks.

Real-Time, Product Status, Energy Status and Positioning Frames are all sent at product startup (there may be up to 10 minutes from startup to receive all these frames).

Message ID	Details of the function	Transmission of data
1	Real Time Frame	Every 15 minutes
2	Product Status Frame	Every week + On event
3	Positioning Frame	Every week + On event
4	Energy Status Frame	Every day

3.2 Real Time frame

The product measures and sends a message containing environmental data every 15 minutes.

Insafe+ PMo - Measurement Real Time Frame for PM / Temp / Hum / Pressure							
Offset	Size (bit)	Bit-range	Data	Description	Valid Range	Scale	Unit
0	8	DB0.7 - DB0.0	Product type	Insafe+ PMo LoRa	0xA1		
8	8	DB1.7 - DB1.0	Message type	Real time frame for PM/Temp/Hum/Pressure	0x01		
16	16	DB2.7 - DB3.0	PM1	PM1 concentration (in µg/m3 or pcs/mL)	0..10000	0-1000µg/m ³	0.1 µg/m ³
					0..65000	0-65000pcs/mL	1pcs/mL
					65535: Error		
32	16	DB4.7 - DB5.0	PM2.5	PM2.5 concentration (in µg/m3 or pcs/mL)	0..10000	0-1000µg/m ³	0.1 µg/m ³
					0..65000	0-65000pcs/mL	1pcs/mL
					65535: Error		
48	16	DB6.7 - DB7.0	PM10	PM10 concentration (in µg/m3 or pcs/mL)	0..10000	0-1000µg/m ³	0.1 µg/m ³
					0..65000	0-65000pcs/mL	1pcs/mL
					65535: Error		
64	10	DB8.7 - DB9.6	Temperature	Temperature (°C) with offset 30°C (e.g : 0 = -30°C, 300 = 0°C, 1000 = 70°C)	0..1000	-30..70°C	0.1°C
					1024: Error		
74	7	DB9.5 - DB10.7	Humidity	Humidity (%RH)	0..100	0..100%RH	1%RH
					127: Error		
81	11	DB10.6 - DB11.4	Pressure	Pressure (hPa)	300-1200	300-1200 hPa	1 hPa
					2048: Error		
92	1	DB11.3	PM Measurement Unit	PM measurement unit (µg/m3 or pcs/mL)	0: µg/m ³ 1: pcs/mL		
93	3	DB11.2 - DB11.0	Frame Index	Loop counter used to detect frame losses	0..7		

Example :

Raw Frame : A10100F0013C019477ACBF50

Decoded Frame :

Product Type : Insafe+ PMo LoRa

Message Type : Real-Time Frame

PM1 : 24.0

PM2.5 : 31.6

PM10 : 40.4

Temperature : 17.8 °C

Humidity : 44.5 %RH

Pressure : 1013 hPa

PM Unit : $\mu\text{g}/\text{m}^3$

Frame Index : 0

3.3 Product Status frame

This message is sent every 7 days or when at least 1 piece of information changes. The product & sensor status is automatically computed by the product each 24h. Data are sent in the following format:

Insafe+ PMo - Product Status Frame							
Offset	Size (bit)	Bit-range	Data	Description	Valid Range	Scale	Unit
0	8	DB0.7 - DB0.0	Product type	Insafe+ PMo LoRa		0xA1	
8	8	DB1.7 - DB1.0	Message type	Product status frame		0x02	
16	8	DB2.7 - DB2.0	HW Revision	Hardware revision		Enum	
24	8	DB3.7 - DB3.0	SW Revision	Software revision		Enum	
32	3	DB4.7 - DB4.5	Reset source	Last reset cause	0 = HW Reset (Power ON-OFF / Low battery / RST button) 1 = SW Reset (9x Push Button) 2 = Watchdog OVF 7 = Undefined Reset Source		
35	10	DB4.4 - DB5.3	Product working time	Product working time in weeks	0-522	0-522 weeks	1 week
45	2	DB5.2 - DB5.1	PM Global status	Indicates if the sensor is able to communicate accurate PM Data	0=OK; 1=NOK; 3 = Not mounted		
47	8	DB5.0 - DB6.1	PM Detailed status	Bitfield indicating minor errors or HW fault of the PM Sensor	SLEEP_STATE:0 DEGRADED_STATE:1 NOT_READY:2 HEAT_ERROR:3 T_RH_ERROR:4 FAN_ERROR:5 MEMORY_ERROR:6 LASER_ERROR:7		
55	2	DB6.0 - DB7.7	Temp/Hum status	Status of the Temperature / Humidity sensor	0=OK; 1=NOK; 3=Not mounted		
57	2	DB7.6 - DB7.5	Pressure sensor status	Status of the Pressure sensor	0=OK; 1=NOK; 3=Not mounted		
59	2	DB7.4 - DB7.3	CO2 sensor status	Status of the CO2 sensor	0=OK; 1=NOK; 3=Not mounted		
61	2	DB7.2 - DB7.1	NTC1 status	Status of the first contact probe	0=OK; 1=NOK; 3=Not mounted		
63	2	DB7.0 - DB8.7	NTC2 status	Status of the second contact probe	0=OK; 1=NOK; 3=Not mounted		
65	2	DB8.6 - DB8.5	GPS - Module communication	Status of the GPS Module	0=OK; 1=NOK; 3=Not mounted		
67	1	DB8.4	GPS - Antenna type	Antenna type connected to the GPS Module (valid only if GPS is mounted and operational)	0=On Chip, 1=External		
68	1	DB8.3	GPS - Fix status	Status of last GPS Fix (valid only if GPS is mounted and operational)	0=Last fix OK, 1=Last fix NOK		
69	2	DB8.2 - DB8.1	Accelerometer status	Status of the Accelerometer	0=OK; 1=NOK; 3=Not mounted		
71	3	DB8.0 - DB9.6	EEPROM Memory status	Status of the EEPROM memory	0=OK; 1=NOK; 7=Not mounted		
74	3	DB9.5 - DB9.3	Secure Element status	Status of the Secure Element	0=OK; 1=NOK; 7=Not mounted		

77	3	DB9.2 - DB9.0	NFC Memory status	Status of the NFC Memory	0=OK; 1=NOK; 7=Not mounted
80	2	DB10.7 - DB10.6	Battery Charger status	Status of the Battery Charger	0=OK; 1=NOK; 3=Not mounted
82	2	DB10.5 - DB10.4	DC/DC 3V3 status	Status of the 3V3 power supply (for system and sensors powering)	0=OK; 1=NOK; 3=Not mounted
84	2	DB10.3 - DB10.2	DC/DC 5V status	Status of the 5V power supply (for PM and Fan powering)	0=OK; 1=NOK; 3=Not mounted
86	2	DB10.1 - DB10.0	Battery status	Status of the Battery	0=OK; 1=NOK; 3=Not mounted
88	2	DB11.7 - DB11.6	AC Input status	Status of the ~220V AC Input	0=OK; 1=NOK; 3=Not mounted
90	2	DB11.5 - DB11.4	PV Panel status	Status of the Solar Panel	0=OK; 1=NOK; 3=Not mounted
92	1	DB11.3	Working mode	Current working mode of the product	0 = Normal, 1 = Preservation Mode (Measures OFF)
93	3	DB11.2 - DB11.0	Frame index	Loop counter used to detect frames losses	0..7

3.4 Positioning frame

This message is sent few minutes after product startup, every week and after each product move

Insafe+ PMo - Positioning Frame							
Off set	Size (bit)	Bit-range	Data	Description	Valid Range	Scale	Unit
0	8	DB0.7 - DB0.0	Product type	Insafe+ PMo LoRa		0xA1	
8	8	DB1.7 - DB1.0	Message type	ID of Positioning frame		0x03	
16	7	DB2.7 - DB2.1	Latitude - Degrees	Degrees of latitude	0-90	0-128	1°
23	6	DB2.0 - DB3.3	Latitude - Minutes	Minutes of latitude	0-60	0-64	1'
29	6	DB3.2 - DB4.5	Latitude - Seconds	Seconds of latitude	0-60	0-64	1"
35	7	DB4.4 - DB5.6	Latitude - Milliseconds	Milliseconds of latitude	0-100	0-128	10ms
42	1	DB5.5	Latitude - North/South	North=0, South=1	0-1	0-1	1
43	8	DB5.4 - DB6.5	Longitude - Degrees	Degrees of longitude	0-180	0-256	1°
51	6	DB6.4 - DB7.7	Longitude - Minutes	Minutes of longitude	0-60	0-64	1"
57	6	DB7.6 - DB7.1	Longitude - Seconds	Seconds of longitude	0-100	0-128	10ms
63	7	DB7.0 - DB8.2	Longitude - Milliseconds	Milliseconds of longitude	0-1	0-1	1
70	1	DB8.1	Longitude - East/West	East=0, West=1	0-1	0-1	1
71	7	DB8.0 - DB9.2	HDOP	Horizontal dispersion (<1: Very good, <2 : Medium, Else : Bad)	0-128	0-128	x0.1
78	5	DB9.1 - DB10.5	Satellites number	Satellite number used to fix and compute the location	1-32	1-32	1
83	2	DB10.4 - DB10.3	Fix type	Fix type given by the GPS module (normally GNSS fix if OK)	0=No Fix, 1=GNSS Fix, 2=DGPS Fix, 3=Estimated location		
85	13	DB10.2 - DB12.6	Alitutde	Altitude in meters	0-8192	0-8192 m	x1m
98	8	DB12.5 - DB13.6	Product Orientation	Product orientation (relative to nominal orientation)	0=0° (good orientation) 1=90 2=180° 3=270° 4=Flat FF=Undefined		
106	3	DB13.5 - DB13.3	Reserved	Reserved		Reserved	
109	3	DB13.2 - DB13.0	Frame index	Loop counter used to detect frames losses		0..7	

3.6 Energy Status frame

This message is sent every day. Data are sent in the following format:

Insafe+ PMo - Energy Status Frame							
Offset	Size (bit)	Bit-range	Data	Description	Valid Range	Scale	Unit
0	8	DB0.7 - DB0.0	Product type	Insafe+ PMo LoRa		0xA1	
8	8	DB1.7 - DB1.0	Message type	ID of Energy Status frame		0x04	
16	13	DB2.7 - DB3.3	Battery voltage	Battery voltage	0-8100	0-8100	x1 mV
29	10	DB3.2 - DB4.1	DC/DC 3.3V voltage	3V3 converter voltage	0-1000	0-1000	x10mV
39	10	DB4.0 - DB6.7	DC/DC 5V voltage	5V converter voltage	0-1000	0-1000	x10mV
49	8	DB6.6 - DB7.7	BSR	Battery internal resistance	0-250	0-2500	x10m Ohm
57	8	DB7.6 - DB8.7	Solar/AC Input Energy	Energy received from solar panel or AC Input since last sending	0-250	0-250	x1Wh
65	8	DB8.6 - DB9.7	Battery stored Energy	Energy stored in battery since last sending	0-250	0-250	x1Wh
73	8	DB9.6 - DB10.7	Time Fan ON	Time Fan ON since last sending	0 - 144	0 - 1440	x10min
81	8	DB10.6 - DB11.7	Time Charging ON	Time charging the battery since last sending	0 - 144	0 - 1440	x10min
89	4	DB11.6 - DB11.3	Reserved	Reserved		Reserved	
93	3	DB11.2 - DB11.0	Frame index	Loop counter used to detect frames losses		0..7	

4.Revision History and product batch number

4.1 Technical guide changelog

Document revision	Details	Date
A	Created	17/09/2020
B	Installation Details	02/11/2020